

Operation Manual

Oreo Hanse 458
2019



Control Panel

Yacht Control Panel Overview

The yacht control panel is an essential electronic device that allows remote control of various onboard systems, including:

- ✓ **Windlass** (anchor control)
- ✓ **Thrusters** (maneuvering assistance)
- ✓ Navigation lights
- ✓ Alarms & video surveillance
- ✓ Windshield wipers
- ✓ **Engines** and fuel, water, and oil levels
- ✓ Generators and other equipment

Why the control panel is important:

- Monitors the yacht's health – Ensures all systems are functioning properly.
- Keeps you safe – Provides control over critical safety features and alerts.

⚡ Left Side:

- ⚡ Interior Lights
- ☀️ Navigation Lights
- ⚓ Anchor Lights
- 🚢 Steaming Lights
- ❄️ Refrigerator/Freezer
- 💧 Fresh Water Pump
- 💧 Bilge Pump (Manual Override)
- 📡 Navigation Electronics
- ⚙️ Anchor Winch Control
- ⚙️ Winches Control

Right Side:

- 💡 Saloon Lights
- □ LED Strip (Saloon)
- 🍳 Kitchen Lights
- □ F4 (Spare)
- 🌙 Cockpit Light
- □ F6 (Spare)
- □ F7 (Spare)
- □ F8 (Spare)





Battery Charger Location

Battery Charger (Cristec Charger) Overview

A **battery charger** (or recharger) is a device that **stores energy** in a battery by running an electric current through it.

The **Cristec Charger** ensures **maximum power supply** with **auto-ranging**, meaning it can adapt to different voltage inputs wherever you are.

Where to Find It:

- Left of the Chart Table  
- Behind the Couch  

Interior / Exterior Radio

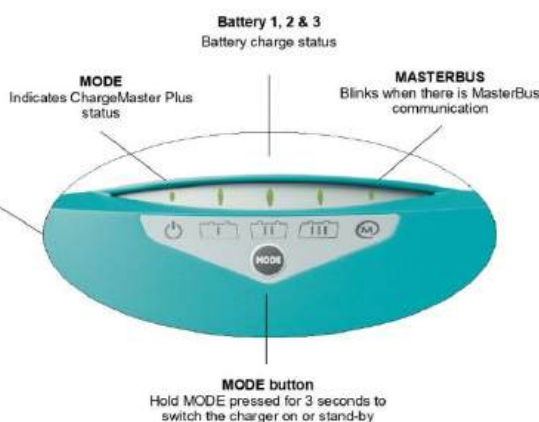

Interior / Exterior Radio

How the Radio Works

Radio communication operates by transmitting and receiving electromagnetic waves.

◆ Transmission:

✓ A **radio signal** is an electronic current that moves back and forth rapidly.

✓ A **transmitter** sends out this signal via an **antenna**.



◆ Reception:

✓ A **receiver** picks up the transmitted waves.

✓ The signal is then converted into **sound**, which is heard through the radio speaker.

⚠ **Tip:** Ensure the radio is properly tuned to the correct frequency for clear communication.



Dial	<ul style="list-style-type: none"> • Turn to adjust the volume. • When adjusting the volume, press to switch between zones. • Turn to move through the menus or adjust a setting. • When in a menu, press to select the highlighted option. • Press and hold to activate certain functions such as opening the radio presets or muting all connected stereos from the mute screen (<i>Muting all Connected Stereos</i>, page 6).
	Press to change the source. TIP: You can turn the dial to browse, and press the dial to select the source. You can also swipe the screen up and down, and touch a source on the screen. Press and hold to open the GROUPS menu when connected to a Fusion PartyBus™ network (<i>Fusion PartyBus Networking</i> , page 23).
	Press to open the menu.
	<ul style="list-style-type: none"> • Press to turn on the stereo. • Press to mute the audio. • Press and hold to turn off the stereo or all stereos on the network. • Press and hold for longer than 10 seconds to reset the stereo.

VHF

VHF Transceiver Overview

A **Very High Frequency (VHF) transceiver** is a communication device that includes both a transmitter and a receiver, operating in the **30 MHz to 300 MHz** frequency range.

◆ Key Features:

✓ **Frequency Range:** 30 MHz – 300 MHz

✓ **Wavelength:** 1 meter (39.37 inches) to 10 meters (393.70 inches), depending on the frequency used

✓ **Used for:** Marine communication, aviation, emergency services, and broadcasting

⚠ **Tip:** Ensure the VHF radio is set to the correct **channel and frequency** for clear and effective communication.

📄 Main Controls:

1. Channel Knob / Press to Select – Turn to select channels, scroll menus, enter alphanumeric values, and adjust backlight level.

- **Short press:** Confirm selections
- **Long press:** Open "MY CHANNELS".

2. 🗣️ **VOL / SQL (Volume & Squelch)** – Adjusts volume and squelch levels.

- **Short press:** Toggle between volume and squelch (indicated by a small triangular arrow).
- **Turn clockwise:** Increase setting.
- **Turn counterclockwise:** Decrease setting.
- **Long press:** Open "SHORTCUTS."

3. ❌ **X (EXIT)** – Exit menus, clear incorrect entries, or return to the previous screen.

📡 Radio & Handset Functions:

12. ● **16 (Priority Channel)**

- **Short press:** Switch to priority channel (default: CH16).
- **Press again:** Return to the previous channel.

13. 🚨 **DISTRESS (Emergency Call)**

- **Short press:** Select distress type from a list.
- **Long press:** Send an 'undesigned' distress call, alerting all DSC-equipped radios within range (includes position info if available).

Key functions

The following describes the direct functions of the keys/knobs. Where necessary, additional detail on any menus accessed by keys is covered in following chapters.

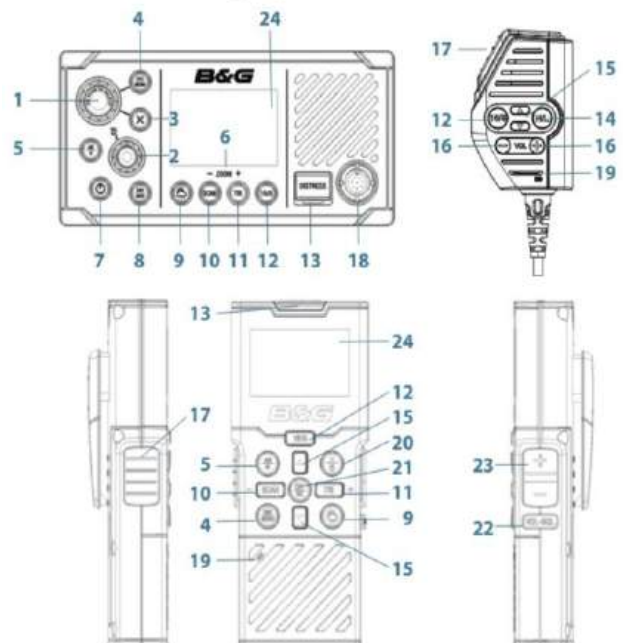

15. ▲ ▼ **Channel Change (Handset Mic & Wireless Handset)**

- **Short press** (▲): Move up one channel.
- **Short press** (▼): Move down one channel.
- **Hold**: Rapidly scroll through channels.

16. 🔊 **VOL +/- (Volume) (Handset Mic Only)**

- **Short press (+)**: Increase volume.
- **Short press (-)**: Decrease volume.

17. 🗣️ **PTT (Push-to-Talk) (Handset Mic & Wireless Handset)**

- **Press & hold**: Transmit message. The radio cannot receive while transmitting.

18. 🎤 **Handset Microphone (Front Connection)**

- Plug in the removable microphone to the front or rear of the radio.

19. 🗣️ **MIC (Microphone) (Handset Mic & Wireless Handset)**

📦 **Dual Energy Power Supplies and Battery Chargers**

These units are specifically designed and developed for:

- ⚡ Charging and maintaining voltage on lead-acid batteries.
- ⚡ Providing consistent and uninterrupted power supply (main or backup).

📍 Location:

You will find it in the **chart table area**.



General Switches

Battery Master Switch Overview

The **battery master switch** serves two key functions:

- ✓ **Battery Isolator** – Disconnects the battery to prevent drain when not in use.
- ✓ **Theft Deterrent** – Can disable the electrical system to prevent unauthorized use.

◆ Features:

- Commonly used in: Marine, transportation, and automotive applications.
- Impact-resistant housing for durability.
- Detachable key for added security and theft prevention.

General Switch 220V

⚡ General Switch 220V – Quick Reference

- 📍 **Location:** Inside the exterior port locker
- ⚡ **Function:** Controls the shore power supply to the boat
- 🔄 **To Turn ON:** Flip the switch to the ON position (usually marked "I" or "ON")
- 🔴 **To Turn OFF:** Flip the switch to the OFF position (usually marked "O" or "OFF")



Service



📍 Service Battery Switch – Quick Guide (Bullets & Symbols)

- 📍 Located on the right side of the chart table
- 🛋️ Found under the living room cushion

Engine

Main Switch

- 📍 Located in the stern left cabin (pink pin)
- 🟠 Positioned behind the door (brown square)
- 🔴 Used to turn off the boat's currents (red circle)

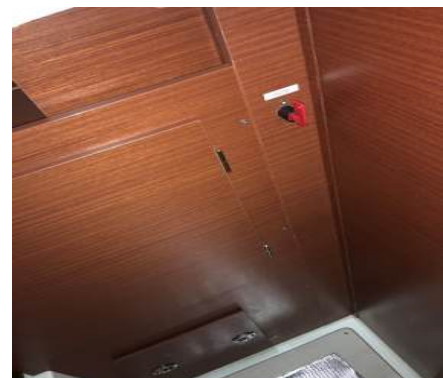

Jet Thruster

Jet Thruster Battery Power Switch – Quick Reference with Symbols

- **Location:**
 - Bow Left Cabin 🚪
 - Under the Bed Mattress (lift to access) 📏
- **Function:**
 - Turns off the Jet Thruster battery power 🌊
- **Purpose:**
 - Isolates power for maintenance or shutdown 🔴 🔧

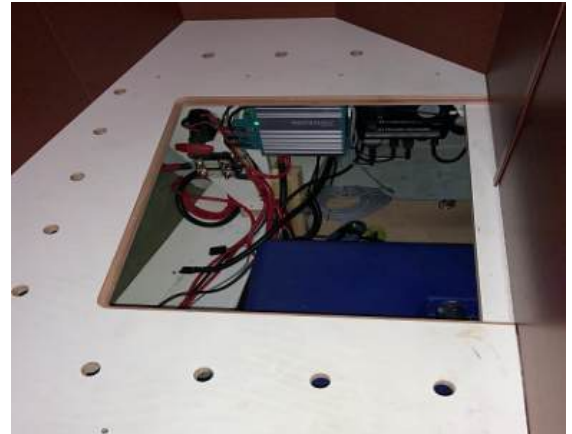

Thermal Fuses

Fuses: Function & Usage

Fuses are protective mechanisms placed in an electrical circuit to interrupt power supply when excessive current flows due to short circuits or overloads. Their primary purpose is to protect wiring and electrical components from damage.

⚡ Key Characteristics:

- ✓ Interrupt power in case of overload or short circuit.
- ✓ Always installed after circuit breakers for additional safety.
- ✓ Never installed in-ground conductors to avoid grounding issues.

🔧 Usage of Fuses:

- 1] Protect electrical wiring from overheating or damage.
- 2] Ensure onboard electrical safety by preventing fire hazards.
- 3] Automatically break the circuit when an excessive current surge occurs.

⚠ **Tip:** Regularly check and replace blown fuses to maintain proper electrical function on the yacht.

Anchor fuse

Windlass Fuse Reset Instructions (with Specific Symbols)

Location: Under the Chart Table

⚠ If the Fuse is OFF

- **Fuse Status:**
!! The **yellow plastic** part visibly protrudes at **position: 0**
○ (Circle indicates the OUT/OFF position)

🔧 To Reset the Fuse

- 🖐 **Step 1:**
Use your fingers to **press down** the yellow plastic part
- ⬇ **Step 2:**
Push it **from position 0** (○) until it **clicks into position 1** (●)

✅ Test Windlass Operation

- ⚡ If the windlass **is working:**
● All set! (OK)
- ❌ If the windlass **still does not work:**
 - 🔄 Repeat above reset steps
 - 🛠 Check for further **electrical/mechanical issues**



Bilge Pump / VHF

Bilge Pump & VHF Fuse – Quick Reference

- 📍 Located on the right side of the chart table
- 🛋 Also found under the living room cushion

Resetting the Fuse (Step-by-Step)

1. **Check the fuse**
If the fuse has tripped, a yellow plastic piece will be protruding downwards almost vertically.
2. **Reset the fuse**
Using your fingers, press the yellow plastic piece upwards until it reaches a horizontal position and clicks into place.

3. **Operation test**

Ensure everything is working properly after resetting by doing a quick functional test.

This procedure helps restore power to the bilge pump and VHF circuits. The yellow plastic indicator provides a visual cue when a reset is needed, making regular checks simple and efficient.

Thruster

⚡ Thruster Thermal Fuse – Quick Guide

- 📍 **Located:** Right side of the chart table
- 📦 **Also found:** Under the living room cushion

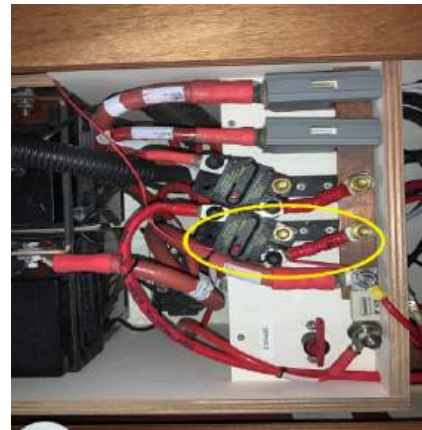

Batteries Location

📌 What is a Battery?

A **battery** is a device that:

- ⚡ Stores chemical energy and converts it into electrical energy.
- 🔋 Uses chemical reactions to create the flow of electrons between electrodes.
- 🔌 Generates electric current to power various devices.



Service

📌 Service Batteries

- 📍 Located on the right side of the chart table
- 📦 Found under the living room cushion



Engine

📍 **Engine Battery Location:**

📌 **You will find the engine battery** inside the **engine room** 🛠️

Thruster

📌 **Thruster Batteries Location – Quick Guide with Symbols**

- 📍 **Where to Find Them:**
 - Bow Cabins 🏠
 - Under the Beds 🛏️



Water System

💧 **Freshwater Pumps Overview:**

🔧 Freshwater pumps deliver water to fixtures onboard a boat, making life aboard more comfortable and convenient.

◆ **Pressurized Water Systems:**

Provide water "on tap" for:

- 🚰 Dishwashing
- 🚿 Showers
- 🔧 And other applications



Water heater

Water Heater Panel

- 📍 Located on the corner of the couch
- 🟡 To activate the Water Heater, press the button
- ☀️ When in operation, an orange light will appear in the middle of the button



Location bilge pump



💧 Bilge Pump Details:

- Function: Removes bilge water from the yacht 🚤.

📍 Location:

- On the floor in front of the stairs.

⚙️ Operation Tips:

- The bilge pump is **automatic** 🤖.
- Ensure the **corresponding button is always ON** ✅.

Operation of toilet pumps

🚽 Toilet Details:

- **Importance:** One of the most used pieces of equipment on your boat 🚤.
- **Operation:** Correct usage is crucial for:
 - ⚓ Safety of the crew
 - ⚓ Comfort onboard



1. Open inlet and outlet seacocks (and secondary valves if fitted).
2. Half fill the bowl with warm fresh water.
3. Keeping the Flush Control Lever in the Shut (➡) position, pump out the warm water.

Normal use

Open inlet and outlet seacocks (and secondary valves if fitted).
 Before use, ensure that there is enough water in the bowl to prevent the toilet paper from becoming compacted at the bottom of the bowl. If the bowl is empty, move the Flush Control Lever to the Open (←) position and pump the handle up and down until the flushing pump is primed and water enters the bowl. Then Shut (→) the Flush Control. Operate the pump with long, smooth strokes for efficient and easy operation. During use, pump as necessary to keep the contents of the bowl low enough for comfort.

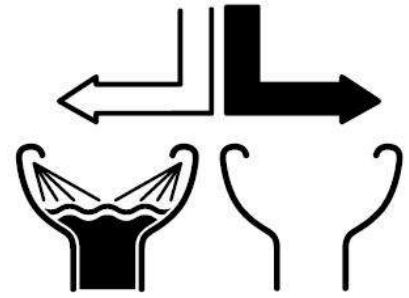

After use, keep the Flush Control Shut (→) and pump until the bowl is empty.

When the bowl is empty, Open (←) the Flush Control again, and continue to pump until all waste has either left the boat or reached the holding tank (allow 7 complete up/down strokes per meter (yard) length of discharge pipework).

NOTE: Do not put in: Sanitary Towels, Wet Strength Tissues, Cotton Wool, Cigarettes, Matches, Chewing Gum, or any solid objects, Petrol, Diesel, Oil, Solvents of any kind, or water more than hand hot.

Operation of shower pumps

🔧 Shower Pump Operation

On this boat, the **shower pumps** are **not automatic**. Here's how to operate them:

1. Manual Operation:

- Turn the black button ON to start the pump.
- Turn it OFF when you're done using the shower.

2. With Negative Head Kit:

- When the pump is fitted with a special negative head kit, you can operate the shower by:
 - Turning on the mixer valve.
 - Turning on the switch once to start the pump.
- The pump will run as normal once started.

⚠️ Important:

Always remember to turn off the shower pump after use to conserve energy and avoid unnecessary wear.



Operation / Location of Waste Tanks / Valves

👉 Stop-and-Waste Valve Operation

A **stop-and-waste valve** is used in irrigation systems to prevent waste from freezing and to manage wastewater. Here's how it works on the yacht:

1. Operation:

- **When the valve is vertical** to the tube, it is **closed**, and the waste goes to the waste tank.
- **When the valve is parallel** to the tube, it is **open**, and the waste is emptied into the sea.

2. Location of Waste Valves:

- **1st valve:** Found **inside the cap** at the **bow toilet**.
- **2nd valve:** Found at the **stern toilet**. Look to the **left**, open the cap, and you will find it.

Seacocks

Seacocks are of the ¼-turn type:

- OPEN position: handle in the direction of the seacock body.
- CLOSED position: handle perpendicular to the seacock body.

Vanne ouverte

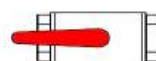

Vanne fermée

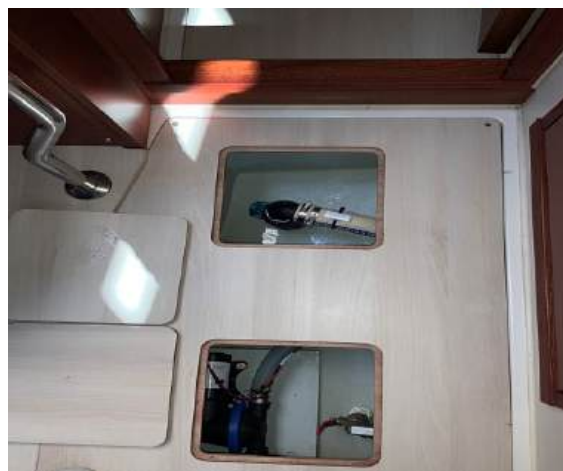
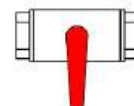

Oven/Stove

🔥 Turning On the Oven or Hob

To safely turn on the oven or hob, follow these steps:

1. **Press the respective switch** inwards.
2. **Turn the switch clockwise** while holding it in.
3. **Light the hob** with a lighter and **hold for 5 seconds** to ensure the flame stays on.
4. **Release the switch** after 5 seconds.
 - If the flame does not stay on, try holding the switch in for a bit longer.



Location of gas valves inside

🔑 Gas Inlet Insulation in the Kitchen

If you need to insulate the gas inlet under the oven, follow these steps:

- 1. Location:** Open the cupboard under the oven to find the gas outlet valve.
- 2. Operation:**
 - Parallel to the pipe: The valve is open.
 - Perpendicular to the pipe: The valve is closed.



Fridge Interior / Operation

❄️ Proper Refrigerator Use

Essential for maintaining cooling efficiency, saving energy, and extending its lifespan.

✅ Best Practices:



- ◆ Pre-cool before the trip 🍷
 - If possible, turn on the refrigerator while connected to 220V power before departure.
- ◆ Use pre-chilled products 🧊
 - Placing already frozen or chilled food and drinks reduces the fridge's workload.
- ◆ Minimize door openings 🚪
 - Each time you open the door, warm air enters, increasing power consumption.
- ◆ Fill the fridge properly 📦
 - A full fridge maintains temperature better.
 - If not full, use ice packs or frozen water bottles.
- ◆ Set the correct level ⚙️
 - Ideally, set the temperature between 4–5.



Engine

Marine Engine

A **marine engine** is a machine that:

-  Converts energy from fuel into mechanical energy.
-  This mechanical energy is used to create motion, powering boats, ships, or other watercraft.

Emergency Engine Shutdown

In case of **emergency** (and **only** in this case), follow these steps to turn off the engine:

- Location:** Go to the rear right cabin where you'll find a picture of the engine, similar to the one shown in the photo.
- Shutdown Process:**
 - Press the red button down.
 - Rotate the button to the left to turn off the engine.



Engine Oil Check

Checking Engine Oil

To check your engine oil, follow these steps:



- Location:** Go to the **right rear cabin**, where you'll find a picture of the engine oil, similar to the one shown in the photo.
- Check the Oil:** Use the visual reference in the cabin to inspect the engine oil levels and condition.



Engine Control Panel

Engine Control Unit (ECU)

An **Engine Control Unit (ECU)**, also known as an **Engine Control Module (ECM)**, is:

-  A type of **electronic control unit**.
-  It **controls a series of actuators** on an **internal combustion engine**.
-  Its primary role is to ensure **optimal engine performance** by regulating critical functions such as fuel injection, ignition timing, and air intake.

⚙️ Turning On the Engine

To start your engine:

1. **Press and hold the power button.**
2. While holding the power button, **press and hold the start button** until the engine starts.



⚙️ Turning Off the Engine

To stop your engine:

1. **Press and hold the stop button.**
2. While holding the stop button, **press and hold the power button** to turn off the engine.

Thruster Controller

⚓ Thrusters on a Boat

Thrusters are specialized propulsion devices used on boats:

- **Propellers face sideways**, allowing the boat to move **sideways through the water** (either bow or stern).
- **Function:** When turned on, they push the bow or stern in the desired direction.

⚠️ If only **one thruster** is used (for example, in the bow), the boat will also turn and change its orientation.



Jet Thruster Operation Guide – Quick Reference with Symbols

🚢 Turning On the Jet Thruster

- ✓ **Press & hold** the adjacent button until the indicator turns **blue** ●

🕹️ Steering with the Thruster

- ➡️ **Press Right:** Moves the boat right (starboard)
- ⬅️ **Press Left:** Moves the boat left (port)

Autopilot Operation

Autopilot

If a compatible autopilot computer is connected to the system, autopilot functionality is available in the system.

The system does not allow for more than one autopilot computer on the network.

The display unit automatically detects the autopilot computer available on the network and presents settings, configuration and user options for the connected computer.

For details about installing and configuring an autopilot computer, refer to the separate manuals that come with the autopilot computer.

Safe operation with the autopilot

⚠ Warning: An autopilot is a useful navigational aid, but DOES NOT replace a human navigator.

⚠ Warning: Ensure the autopilot has been installed correctly, commissioned and calibrated before use.

→ **Note:** You can disengage the autopilot at any time by pressing the **STBY** key on the Triton² Pilot controller.

Do not use automatic steering when:

- In heavy traffic areas or in narrow waters
- In poor visibility or extreme sea conditions
- When in areas where use of an autopilot is prohibited by law

When using an autopilot:

- Do not leave the helm unattended
- Do not place any magnetic material or equipment near the heading sensor used by the autopilot system
- Verify at regular intervals the course and position of the vessel
- Always switch to Standby mode and reduce speed in due time to avoid hazardous situations

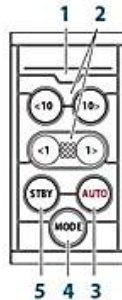

Autopilot controller

The autopilot is controlled by the Triton² Pilot controller.

1 LED - Mode and alarm indicator

2 Port and starboard keys

In Standby mode: press to activate Non Follow Up mode (NFU).

In AUTO mode:

- Press a key to change set heading 1° or 10° to port or starboard
- For boat type set to SAIL: Press and hold both port keys or both starboard keys to start a tack/gybe

In NoDrift mode:

- Press a key to change set heading 1° or 10° to port or starboard

In Wind mode:

- Press to change set wind angle 1° or 10° to port or starboard
- Press both 1° keys to start a tack/gybe

3 AUTO key

Press to activate AUTO mode.

4 MODE key

→ **Note:** Only used when the autopilot is in AUTO or NoDrift mode.

Press once to select mode:

- For boat type set to SAIL: activates Wind mode (**A**)
- For other boat type settings: activates NoDrift mode (**B**)

Press and hold to activate NAV mode (**C**)

5 STBY key

Press to activate Standby mode.

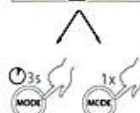

Location of Gas Bottles

Location of Gas Bottles

- Outside – **Starboard Side** ⚓
- Inside the **Locker** 🔒 (open to access)

How to Control the Gas System

- **■ To Open Gas System:**
Turn the **valve clockwise** ■
- **● To Close Gas System:**
Turn the **valve counterclockwise** ✖



Outboard



Starting the Outboard Engine

Follow these steps to start the outboard:

1. **Ensure plenty of gasoline/petrol** is in the **outboard fuel tanks**.
2. **Open the fuel valve** to allow fuel flow.
3. **Open the air valve** from the top to ensure proper airflow.
4. **Set the outboard to neutral** to prepare for starting.
5. **Place the ignition key** into the ignition slot.
6. **Set the throttle to 2/3** for optimal starting performance.
7. **Pull the rope** until the outboard starts running.

Entry Water

💧 Refilling the Water Tank

This yacht has **one water tank**. To refill it:

1. Go to the **bow right side** of the deck.
2. You will find the **water cap** there, labeled with "Water."
3. Open the cap to refill the water tank.



Entries Diesel



Diesel Tank & Refueling

- **Diesel Tank:**
- This yacht has **one diesel tank** 🛢️
- **Refueling Location:**
- **Stern right side on the deck** ⚓
- Look for the **Diesel Cap** labeled "DIESEL" 🔍

Chain marking

🚢 Chain Markings and Anchor Operation

The yacht has approximately 80 meters of chain, with markings every 10 meters as follows:

- 10 meters: ○ (White)
- 20 meters: ● (Blue)
- 30 meters: ● (Green)
- 40 meters: ● (Yellow)
- 50 meters: ● (Red)
- Last 10 meters: ● (Full Red, secured with rope)

Important Attention Points:

1. When dropping the anchor:

- Be cautious not to damage the 🚢 bow side while releasing the chain.

2. When retrieving the anchor:

- When the ● Blue mark appears, it means the anchor is approximately 15 meters below the surface.
- Proceed slowly at this point to avoid damage to the 🚢 bow and 🚢 bowsprit.

3. Windlass motor:

- Ensure the engine is running when using the windlass motor to operate the anchor chain.

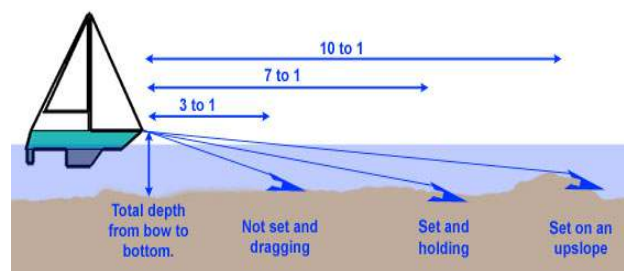

Sails

🚢 Furling Main Sail Operation – Quick Reference with Symbols

Purpose:

For safe and effective manual use of the furling main sail (opening and closing).

🔒 Opening the Main Sail

1. 📧 Set the spigot to "OUT"
2. 🚢 Release the furling ropes while simultaneously pulling the outhaul

🔒 Closing the Main Sail

1. 📧 Set the spigot to "IN"
2. 🙌 Release the outhaul while simultaneously pulling the furling ropes



Genoa Sail

🚤 Self-Tacking Genoa Operation

This yacht is equipped with a self-tacking genoa. Here's how to operate it:

Opening the Genoa:

1. Release the genoa sheet.
2. Take out the genoa furling.

These two actions must be done simultaneously.

Closing the Genoa:

1. Release the furling rope.
2. Pull the genoa sheet.

These two actions must be done simultaneously.

